

GENERAL APPLICATION ML4824-1

100WATT PFC UNIVERSAL OFF-LINE SWITCHING MAGNETICS

Premier Magnetics' TSD-735 Switch Mode Transformer was designed for use with MICRO LINEAR'S ML4824-1 PFC/PWM Combination off-line controller IC, in the Two Transistor Single-Ended Forward Converter Configuration. This converter topology can provide isolated multiple outputs with efficiencies up to 90%. Premier's TSD-735 transformer has been optimized to provide maximum power throughput and to provide the necessary bias voltage for the ML4824-1 and it's auxiliary circuitry.

The ML4824-1 from Micro Linear is highly integrated power supply controller, incorporating a PFC front end operating at 100KHz, and a synchronized PWM switching regulator running @ 50KHz. This combination provides all necessary functions for a Universal-Input, Power Factor Corrected DC power supply in the 50 to 500W output range. The TSD-734 boost inductor and TSD-735 output transformer are critical to the performance of the circuit. Together they define the harmonic reduction, efficiency, output power and the size of the Power Factor Correction and DC output stages.

Below is a typical universal input, high precision application circuit utilizing Micro Linear's ML4824-1 PFC/PWM control IC. The AC mains voltage is power factor corrected and boosted to 382VDC by the PFC half of the ML4824-1 and the TSD-734 PFC boost inductor. The PWM half of the ML4824-1 and the PMGD-03 gate drive transformer then provide the MOSFET gate drives for operating the TSD-735 output transformer which converts the 382VDC hot rail to a regulated 12VDC, 100W output. Recommended component values can be obtained from Micro-Linear's ML4824-1 application notes. Evaluation boards are available from Micro Linear.

SCHEMATIC

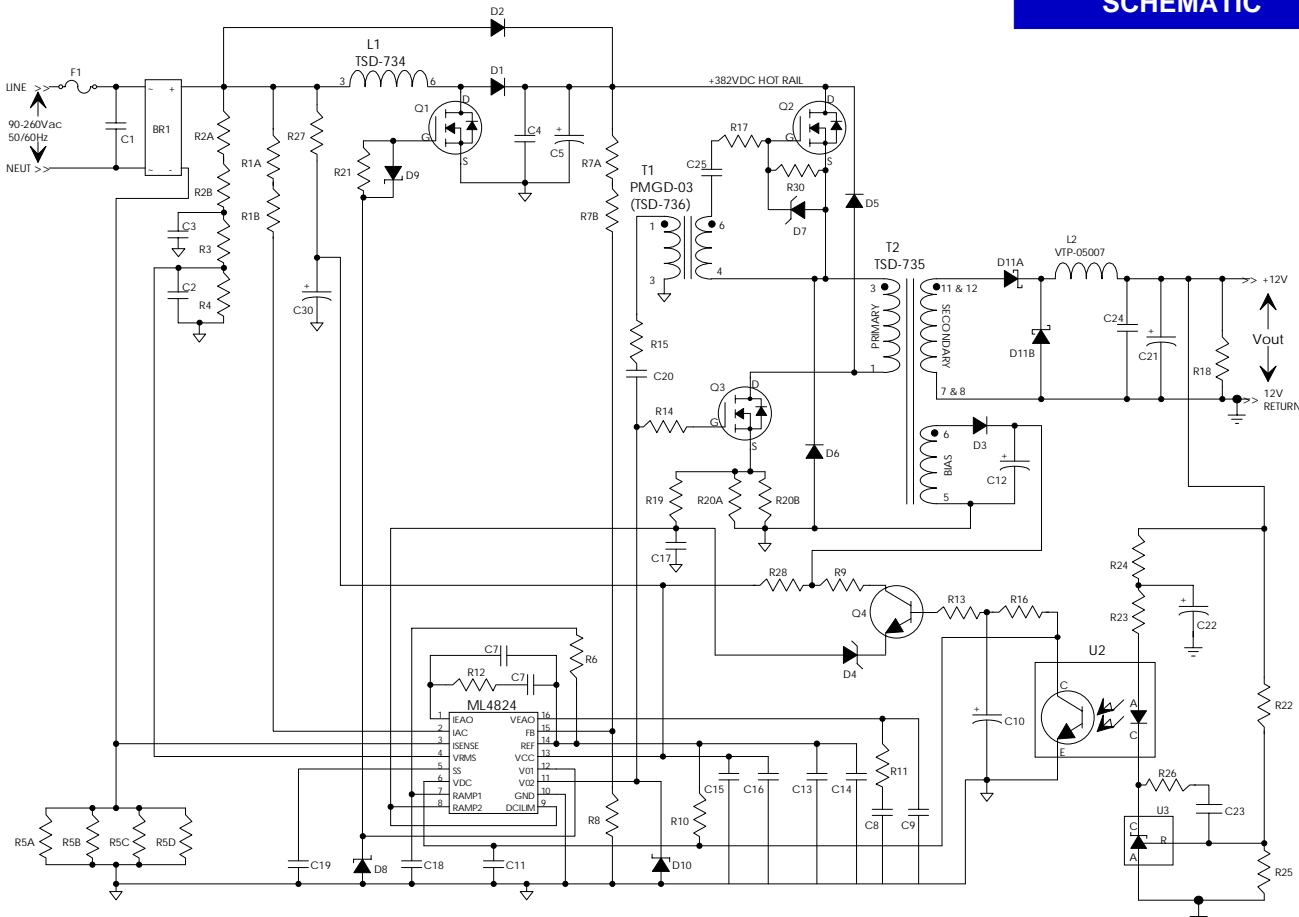

Specifications subject to change without notice.

mlsupport 09/98



GENERAL ELECTRICAL SPECIFICATIONS AT 25°C - OPERATING TEMPERATURE RANGE 0°C TO +70°C

The following magnetics have been designed for use with a variety of Micro Linear semiconductors. To receive complete specifications & application information, please contact the factory or fill out our [Literature Request](#) form to receive the respective part number detail data sheet.

PART NUMBER	Micro Linear I.C. Part Number	APPLICATION INFORMATION	Package
TSD-734	ML4824	PFC Boost Inductor, ML4824-1 EVAL, 100W @ 50KHz	E375
TSD-735	ML4824	Main Switching Transformer, ML4824-1 EVAL, 100W @ 100KHz	EE30
TSD-1047	ML4824	PFC Boost Inductor, ML4824-2 EVAL, 100W @ 100KHz	E375
TSD-1048	ML4824	Main Switching Transformer, ML4824-2 EVAL, 100W @ 200KHz	EI33/29
PMGD-03	ML4824	Gate Drive Transformer (formerly TSD-736), ML4824-1 EVAL	EP7
TSD-845	ML4826	PFC Boost Inductor, ML4826 @ 500W	E55/21
TSD-835	ML4826	Main Switching Transformer, ML4826, 500W Multiple Outputs	ETD-49
TSD-939	ML4826	PFC Boost Inductor, ML4826 @ 650W	E55/21
TSD-938	ML4826	Main Switching Transformer, ML4826, 650W Multiple Outputs	E55/21
TSD-746	ML4831	Boost Inductor, T1 on ML4831 220V EVAL Board	EF25-VERT
TSD-917	ML4831	Boost Inductor, T1 HORZ version on ML4831 220V EVAL Board	EF25-HORZ
PMGD-04	ML4831	Gate Drive, T2 on ML4831 220V EVAL Board (formerly TSD-747)	EP10
TSD-748	ML4831	Main Switching Transformer, T4 on ML4831 220V EVAL Board	EF25-VERT
TSD-749	ML4831	Current Sense Transformer, T5 on ML4831 220V EVAL Board	EF25-VERT
TSD-789	ML4821	T1 on ML4821-EVAL, PFC Controller	PQ40
TSD-780	ML4831	Main Switching Transformer, T4 on ML4831 277V EVAL Board	EF25-VERT
TSD-843	ML4831	Main Switching Transformer, T4 HORZ version ML4831 277V EVAL	EF25-HORZ
TSD-800	ML4831	Main Switching Transformer, T3 on ML4831 220V Low Cost EVAL	EF25-VERT
TSD-801	ML4831	Power Transformer, T3 Variation on ML4831 220V EVAL Board	EF25-VERT
TSD-918	ML4831	Power Transformer, T3 HORZ version Variation on ML4831 220V	EF25-HORZ
TSD-802	ML4831	Main Transformer, T4 Variation on ML4831 220V EVAL	EF25-VERT
TSD-919	ML4831	Main Transformer, T4 HORZ version Variation on ML4831 220V	EF25-HORZ
TSD-831	ML4831	Boost Inductor, T1 on ML4831 120V EVAL Board	EF25-VERT
TSD-844	ML4831	Boost Inductor, T1 HORZ version ML4831 120V EVAL	EF25-HORZ
TSD-902	ML4831	100KHz ZVS PFC Boost Inductor	E42/20
TSD-903	ML4831	100KHz ZVS PFC Resonant Inductor	E2425
TSD-882	ML4832	Boost Inductor, T1 on ML4832 220V EVAL Board	EF25-VERT
TSD-965	ML4833	Boost Inductor, T1 on ML4833 220V Dimming EVAL Board	EF25-VERT
TSD-1086	ML4833	Boost Inductor, T1 HORZ version, ML4833 220V Dimming EVAL	EF25-HORZ
TSD-1082	ML4833	Boost Inductor, T1 on ML4833 120V Dimming EVAL Board	EF25-VERT
TSD-1087	ML4833	Boost Inductor, T1 HORZ version, ML4833 120V Dimming EVAL	EF25-HORZ
TSD-892	ML4833	Boost Inductor, T4 on ML4833 220V Dimming EVAL Board	EF25-VERT
TSD-1085	ML4833	Boost Inductor, T4 HORZ version, ML4833 220V Dimming EVAL	EF25-HORZ
TSD-756	ML4863	Flyback Transformer, Vin = 3.3V, Vout= 3.3V, 5.0V & 12V	EF25-VERT
TSD-904	ML4900	15A Powdered Iron inductor, 1.4uHy	Toroid